

INSTALLATION & OPERATION GUIDE

AT
**ADVANCED
TECHNOLOGY**

M O D E L S
AT8000
AT8200
**ADVANCED
TECHNOLOGY**
IN-WALL LOUDSPEAKERS



BLENDING HIGH FIDELITY AND ARCHITECTURE®

Congratulations!

Thank you for choosing Advanced Technology In-Wall Loudspeakers from Niles. With proper installation and operation, you'll enjoy years of trouble-free use.

Niles manufactures the industry's most complete line of custom installation components and accessories for audio/video systems. For a free full line catalog write: **Niles, Catalog Request, P. O. Box 160818, Miami, Florida 33116-0818**

TABLE OF CONTENTS

INTRODUCTION	1
FEATURES AND BENEFITS	1
INSTALLATION CONSIDERATIONS	3
SPEAKER PLACEMENT	5
INSTALLATION FUNDAMENTALS	7
INSTALLATION OF BRACKETS, FRAMES AND GRILLES IN NEW CONSTRUCTION	12
INSTALLATION OF BRACKETS, FRAMES AND GRILLES IN EXISTING WALLS	14
INSTALLATION OF THE SPEAKER AND GRILLE IN NEW OR EXISTING CONSTRUCTION	15
OPERATION	17
SPECIFICATIONS	18
WARRANTY REGISTRATION CARD	20
LIMITED WARRANTY	21

Introduction

The AT or Advanced Technology group of In-Wall Loudspeakers are designed to deliver truly stunning performance with optimum installation flexibility. All models in the AT series are constructed using the highest quality components and utilize advanced materials technology to create speakers capable of reproducing both music and movie soundtracks with stunning realism and sonic impact. They are perfect anywhere that quality of sound is the most important consideration.

An AT8000 Series Speaker Kit; AT8000 Series Bracket Kit; and an AT8000 Series Frame/Grille Kit are required to install one AT8000 Series In-Wall Loudspeaker in either new or existing construction.

Features and Benefits

High Performance Woofer and Tweeter Designs

Both the AT8000 and AT8200 incorporate woofer designs which feature inverted dust caps, butyl rubber surrounds, and Niles exclusive BumpBack™ magnet structure to provide powerful and accurate bass response. Additionally, both models feature tweeters housed in a zero-diffraction swiveling enclosure which can be positioned up to 15 degrees off axis to deliver optimum clarity regardless of speaker placement or listening position.

AT8000

Interlaced Carbon/Glass Fiber Woofer

The AT8000's 8" woofer is constructed of carbon and glass fibers which are not only lighter and more rigid than polypropylene, but are interlaced in a pattern that reduces cone breakup and effectively lowers distortion.

Hyperbolic Tri-Laminate Dome Midrange and Zero-Diffraction Swiveling Tweeter*

The AT8000's 1-1/2" midrange driver and 1" tweeter both share a tri-laminate design consisting of an inner textile layer which forms the dome, a high damping layer to kill unwanted resonances, and an outside layer of urethane to add stiffness and prevent breakup modes.

AT8200

Aluminum/Urethane Composite Woofer

The AT8200's 8" woofer is constructed of a composite of aluminum and urethane which is extremely light, highly efficient, and offers superior damping characteristics.

Hyperbolic Aluminum/Urethane Dome Midrange and Zero-Diffraction Swiveling Tweeter*

The AT8200's 1-1/2" midrange and 1" tweeter incorporate the same aluminum/urethane composite used in the construction of the AT8200's woofer. The result is a very natural sounding speaker capable of reproducing mids and highs with superb detail and accuracy.

Computer Optimized Crossover with Acoustical Configuration Controls

The second order Linkwitz-Riley crossover is computer optimized and constructed of premium components for unparalleled sonic performance. The baffle-mounted Tone Controls provide installers with Bass, Midrange and Treble adjustment in four increments (-2dB, Flat, +2dB, +4dB). These controls can be used to fine tune the speakers performance or to compensate for less than ideal room acoustics. (For more information, see **Setting the Tone** on page 15.)

BumpBack™ Woofer Magnet

Niles engineers have utilized a unique magnet construction allowing far greater "throw" or voice coil excursion. This enables Niles AT loudspeakers to play louder without mechanical distortion or "bottoming".

Patent Pending

X-Matrix™ Reinforced Baffle

The X-Matrix baffle design uses specially molded ribs to add rigidity to the baffle assembly. The end result is better bass and improved midrange detail.

Weather Resistant Construction

The AT8000 and AT8200 loudspeakers feature drivers which are impervious to moisture; the grille (sold separately as part of the AT8000 Series Frame and Grille kit) is made of aluminum, and all exposed hardware is constructed of stainless steel.

Absolutely Flush to the Wall Appearance

The unique mounting system of the AT loudspeakers powerfully clamps the frame to the bracket, sandwiching the wall material between them. Because the clamping action is totally uniform around the frame, there are no shadows or gaps between the wall and the frame. Additionally, the Niles mounting system is carefully optimized to stiffen the surrounding drywall and prevent it from resonating. You hear only the music, not the drywall.

Easy Retrofit Installation in your Existing Home

Designed for ease of installation, the Niles mounting system makes retrofit installations simple and fast. A supplied template assures fast and accurate hole cutting. The bracket slips behind the drywall and the screws secure the bracket to the frame, sandwiching the drywall between them. The speaker baffle attaches to the frame, and the grille mounts over the speaker.

Three Stage Installation System for Remodels or New Construction

You install only the parts you need for a particular stage of construction. When the framing and wiring are finished, you install the bracket. After the drywall is up, but before the painter begins to paint, you install the frame and provide the painter with the aluminum grilles so that they can be painted to match the surroundings. Only when construction is completely finished do you put the valuable speaker in the wall. You don't have to mask or prep the speaker for painting, and worries about theft during the final phases of construction are never an issue!

Eight Ohm Impedance

The AT8000 and AT8200 speakers are designed to be compatible with most amplifiers. Their eight ohm impedance is an easy electrical load for most amplifiers to drive.

Low Diffraction, Paintable Aluminum Grilles

AT speakers are available with aluminum grilles. The powder-coated aluminum grille has hundreds of precisely sized perforations, creating an acoustically transparent grille.

Infrared Sensor Mount

The speaker baffle has a locator designed for the Niles MS-1 MicroSensor,™ a miniature infrared sensor. The MS-1 installs discretely behind the aluminum grille and therefore minimizes wall clutter in your home. When you want to control your equipment, you simply point your remote control at the speaker from up to 15 feet away.

Figure 1
Model AT8000 Shown

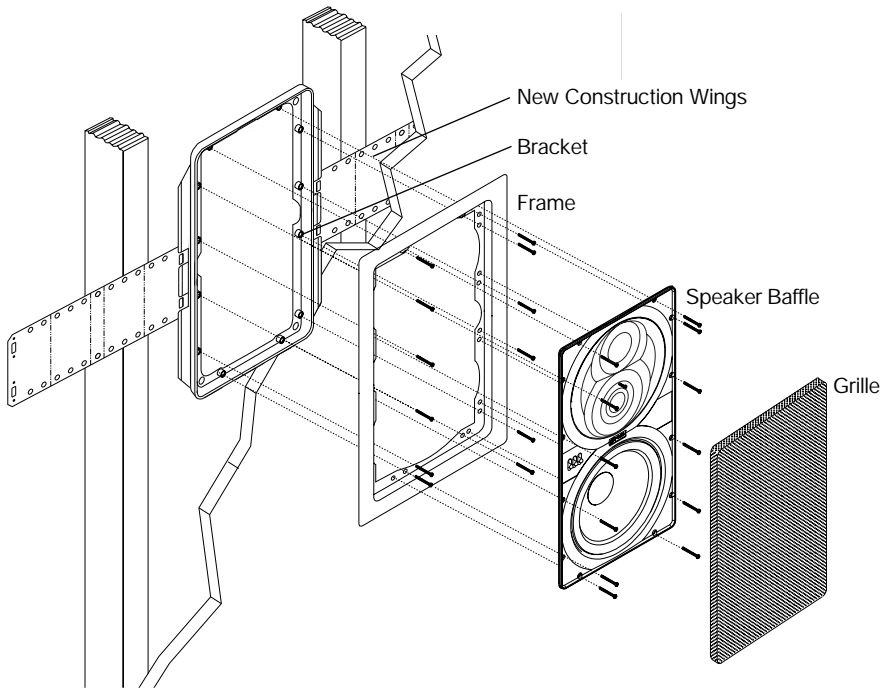

Installation Considerations

Recommended Amplifier Power

For satisfactory performance, we recommend an amplifier with a power rating of twenty to two hundred watts for the AT8000 and AT8200 speakers. Curiously, most speakers are not damaged by large amplifiers but by small amplifiers. If your system is playing loudly, a small amplifier will run out of power very quickly. When an amplifier runs out of power it creates damaging “clipping” distortion. A large amplifier will play at the same volume without distorting. (For more information about clipping distortion, see the section on **Operation**, on page 17.)

Incorporating a Local Volume Control

In a multi-room system there is one indis-

pensible control for true convenience—a local volume control. It allows you to adjust the volume of the speakers without leaving the room.

Plan to wire the system so that each pair of speakers has its own volume control built into the wall (think of a volume control as a dimmer switch for sound).

Niles makes a wide range of high performance indoor and outdoor volume controls. They are available in Standard or Decora® style faceplates (just like your light switches and dimmers). Volume controls are connected in line with the speaker, so you must connect the wire from the amplifier to the volume control and then from the volume control to the speaker.

Speaker Wire

Use 2-conductor speaker wire when connecting AT speakers to your receiver or amplifier. For most applications, we recommend you use a minimum of 16 or 18 gauge wire. For wiring runs longer than 80 feet we recommend a minimum of 14 gauge wire. The spring loaded binding post terminals of the AT speakers will accommodate up to 8 gauge wire directly. Banana jack or pin connectors may also be used to allow the connection of larger size wires if necessary.

An IR sensor requires that a 2-conductor shielded wire (West Penn D291 or equivalent) be home run from each sensor location to the main equipment location. This wire is normally run beside the speaker wire at the same time. Typically, the sensor is placed in a location that faces your listening position. Most remote controls will have an effective line of sight range of 18 to 30 feet with any Niles sensor placed in a wall, ceiling, on a cabinet or tabletop. However, when you place a Niles MS-1 MicroSensor behind the perforated alu-

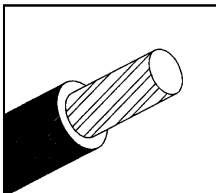

TECH TIP

Wire size is expressed by its AWG (American Wire Gauge) number. The lower the number, the larger the wire, i.e. twelve AWG is physically larger than fourteen AWG.

When wire is to be run inside walls, special jacketing (CL-2 or CL-3) is required to both protect the wire and for fire prevention. In some areas conduit is required. For a trouble-free installation, low voltage wire such as speaker wire must be run in accordance with the National Electrical Code and any applicable provisions of the local building code. If you are unsure of the correct installation techniques, wire jacket or type of conduit to use, consult a professional audio/video installer, your building contractor, or the local building and inspection department.

Incorporating a Remote Control

If you are planning to use a stereo system with a hand held IR remote control, consider the advantages of installing a Niles IR Repeater system. You are able to control all of the functions of your system from the room with the remote pair of speakers. Niles makes a number of IR sensors which install in the wall, in the ceiling, in cabinetry, on tabletops, or even behind the grille of your Niles AT speakers.

minum grille of a speaker, the sensor's effective range is reduced to 9 to 15 feet.

Acoustical Treatment Options

For the best performance from your AT speakers, acoustically treating the surrounding drywall is suggested. In new construction installations, the most practical option is to block off the wall cavity both above and below the area where the speaker will be installed. This will create a "backbox" containing a specific volume of air in which the performance of the AT8000 and AT8200 speakers will be optimized. When installing the AT speakers in a standard wall (16" stud spacing with 2x4 studs) the suggested air volume would be 2540 cubic inches or 52" of space between the top and bottom walls of the "backbox". If the speakers are to be installed in a 2x6 wall, a true backbox may be constructed using 1/2" or 5/8" thick Medium Density Fiberboard (MDF). The dimensions of the enclosure may be varied in terms of height, width, and depth, as long as the interior volume of the enclosure remains approximately 2540 cubic inches.

Although the AT speakers utilize an infinite baffle design which does not require the use of a backbox, critical listeners may appreciate the tighter bass and extended frequency response into the lower octaves that the use of a backbox (or blocking off the wall cavity) will provide. A hole cutting template is provided with the AT8000 Series Bracket Kit. The cutout for the speaker must measure 9-3/4" x 17-1/4".

Insulating the Wall Cavity

When it is not possible to use a backbox, good results can be achieved by treating the interior of the drywall cavity with Dynamat™ or a similar cabinet damping material. At least two linear feet of damping material should be adhered to the rear wall and to the front wall (one foot above and one foot below the cutout) of the wall cavity. Additionally, insulating the wall cavity behind the speaker with fiberglass insulation (e.g., R-19 unbatted insulation) will improve performance. Try to keep the

amount of insulation used for each speaker equal, as bass output will be more consistent. Further improvement can be made by wedging a brace of 1x1 stock between the front and rear walls, both above and below the cutout. Use care when inserting the brace, as too much pressure will create a bulge in the wall.

Speaker Placement

Placement for Critical Listening

If you like to imagine that the band or orchestra is playing in front of you as you listen to music, or you are very conscious of clarity, detail and the textures of the individual instruments, you are a critical listener.

In a home theater, the intelligibility of dialog and action reproduced by the front speakers is paramount! The position of the speakers plays a very important role in how clear the sound is and how a stereo

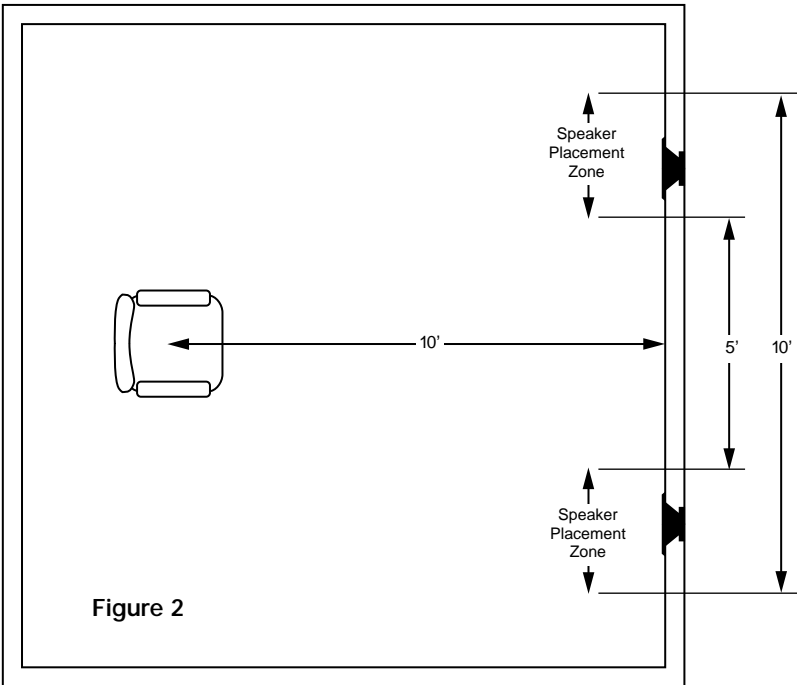

Figure 2

image is created. Here are some guidelines to make the process of placement quick and easy.

Make sure the sound will not be blocked or reflected off of furniture or other objects. You should have a direct line of sight with the front of the speaker. To determine the best position, measure the “listening” distance between the ideal listening position (your favorite chair or couch) and the wall in which you plan to install the speakers. Try to place the speakers so that they are equally distant from your listening spot and at least one half of the listening distance apart (this maintains a large pleasant stereo “image”). In home theater applications where there is a center channel you may choose to space the left and right main speakers farther apart for a “bigger than life” sound with Dolby® encoded movies and TV shows. However, for combined music and movie usage stay within the good placement zone for music. For example; if you are ten feet back from the wall, the speakers should be between five and ten feet apart (See Figure 2).

The Boundary Effect

Corners can affect the bass response of the speaker powerfully! This is called the boundary effect. You will emphasize particular bass frequencies and cancel out other bass frequencies when you place speakers close to the wall/ceiling boundary or a corner wall boundary. This can make the speaker sound excessively boomy and inaccurate to some listeners, while to others it just seems like more bass sound. A good rule of thumb is if you always listen to your current pair of speakers with the bass turned up, you’ll enjoy corner placement. If you keep your preamp or receiver’s tone controls at neutral, try to keep the speakers at least one or two feet from the boundaries of the room. The baffle-mounted Acoustical Configuration Controls may be used to help reduce the affect of corner placement (or the room’s own acoustics)

on the speakers performance. (For more information, see **Setting the Tone Controls** on page 15).

Placement for Varying Listening Positions

If you want the freedom to sit anywhere in a room facing any direction, and/or find that you prefer the “all around you” sound of some car stereos to a conventional “sound stage” facing you, consider the speaker placement techniques professional installers use in restaurants and bars. They place speakers in an array around the listening area, so that the music is always surrounding you, regardless of the direction you face.

The rule of thumb is to add one pair of speakers for every 100 to 200 square feet of listening area. Curiously, this is not so that you can play the music louder, but so that you can play it softer! When you have only one pair of speakers in a large room you will notice that when the sound is perfect in one part of the room, it is too loud near the speakers. By placing more than one pair in the room you will avoid these “hot spots” of loud sound and create more sonic ambience while maintaining clarity and rich sound everywhere.

You can make listener position even less critical by using mono rather than stereo. This can be difficult to achieve with normal stereo amplifiers. However, Niles manufactures Systems Integration Amplifiers which enable one room to be wired in stereo while other rooms are wired in mono! Consult your local Niles dealer for more information.

In smaller rooms or rooms that are infrequently used, you typically can’t justify the expense of more than two speakers. Try to bracket the room with the two speakers. Diagonal placement is a very effective way to stretch the coverage pattern of two speakers. You can also compromise between direct sound (for detail and clarity) and reflected sound (the ambient or “all

around you" effect). By trying to place the speakers so that they create as much reflected sound as possible, you emphasize the ambient effect. They can be up high in the wall or even down low at power outlet height, in the ceiling, near corners, or directed at reflective objects and walls. The more reflected sound there is in the room the stronger the ambient effect at low volumes. You should use moderation, however, otherwise the compromise becomes too one sided and at high volumes the sound will be blurred and less distinct.

Placement for Rear Home Theater Applications

In a home theater, the goal is to reproduce the experience of a great movie theater in our homes. The biggest difference between the two is the rear or surround speaker array in a commercial theater. Here, it is not uncommon to see twenty or thirty speakers around the audience. This huge array of speakers assures that you will feel completely surrounded by the ambient soundtrack of the movie. Film makers try to use the "surround" soundtrack to envelope you in the environment on screen. They will place background music, rain sounds, traffic noise, etc. on the "surround" soundtrack. In a home with a single pair of speakers it is easy for the jungle sounds to sound like they are "in the middle of your head" just like headphones!

A single pair of AT Loudspeakers, properly placed, can create a very convincing simulation of an array of speakers. If you place them near a hard reflecting surface you can make one pair of speakers sound like several. Create as many reflections as possible by mounting the speaker up high in the wall so that the ceiling will act as a powerful reflector. If you place the speakers near a corner, wash the sound down a wall from a ceiling location, or mount the speakers as far away as you can from the listening area, more reflections will occur. However, all of these placement techniques require that

you work your surround sound amplifier channels harder. If the surround sound system you are using has a small five or ten watt amplifier for the rear speakers, stay within five to eight feet of the listening location. If you are using a 25 to 50 watt amplifier you can mount the speakers 10 to 15 feet away from the listening location and still achieve reasonably high volume levels.

Of course, the best way to emulate the sound of multiple speakers is to use multiple speakers. In large or unusually shaped rooms this might be the only way to achieve a good effect. If you like to listen to music surround modes which emulate concert hall acoustics, more than two surround speakers will prove extraordinarily effective. With Niles AT loudspeakers it is easy to add another pair without affecting the decor of the room. However, you will need to use a much more powerful amplifier than that which is built into a typical surround sound receiver or amplifier. Niles makes a number of Systems Integration Amplifiers with proprietary features that make them uniquely suited to enhance a good surround sound system. Consult your Niles dealer for more information.

Installation Fundamentals

Running the Speaker Wire in New Construction

If you have doubts about whether you are capable of installing Niles AT Series speakers in your walls, consult a Niles dealer or professional installer. They have special tools, techniques, and experience to make the impossible possible. The installer can provide you with an estimate before any work is done.

Scheduling and Preparation

Plan to schedule the speaker wiring after the electrical wiring is finished. That way

you can avoid wire routes which could potentially induce hum over the speaker wire. The basic rules are:

- Never run speaker wire through the same hole as an electrical cable.
- Never run speaker wire into the same J-box as electrical cable.
- Avoid running the speaker wire beside the electrical cable. Keep it at least three or four feet distant from any electrical power cable.

Side-by-side wiring is unavoidable in particular spots in every house, just move the speaker wire route away as soon as possible. If construction forces a side by side run for more than ten feet, install metal conduit or shielded speaker wire. Low-voltage wires such as doorbells, intercoms, telephone, security, or television cannot cause interference or hum on your speaker wires, so you can safely run all of them at the same time, through the same holes, side-by-side.

Before you drill any holes, mount the speaker brackets in the desired speaker locations and mount p-rings or open backed J-boxes where the in-wall volume controls and stereo equipment will be.

Safety First!

Wear gloves, safety goggles and head protection when drilling. Avoid nails, they ruin

bits and they can create injury. Pay particular care when using “hole-hogs” and other powerful electric drills; the torque of the drill when suddenly stopped by a nail can break the wrist of a strong man.

Drilling

Use a bit that is large enough for the wires you plan to run. An auger bit is the preferred bit for rough-in wiring. It will actually pull itself through the wood, so that the drill motor, not you, does most of the work. You will be drilling a lot of holes, so this is important.

Always drill the holes in the center of the stud. If you have to notch the stud or drill the hole closer than one inch from the edge of the stud, protect the wire with a nail plate (**See Figure 3**).

When drilling holes in ceiling joists, drill in the center of the joists and try to locate the hole near the end of the joist. **DO NOT** drill through a “gluelam” or any load bearing beam without the direction of your contractor.

Try to line the holes up perfectly, because it makes pulling the wire much easier. A good technique is to snap a chalk line across the face of the studs or against the bottom of the ceiling joists. Then work backward so that you can always see the holes you have already drilled. Paying careful attention to this will save you a lot of time later on!

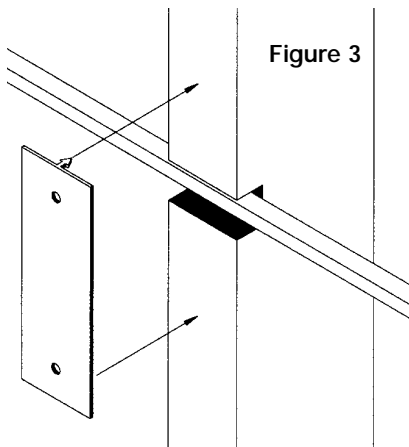

Figure 3

Pulling the Cable

Pull the cable in sections (from the stereo to the volume control, from the volume control to the speaker). Start with the longest sections and use left over wire to complete the short sections. If you plan to pull many rooms at the same time through a central route, walk off the distance to each destination, add a generous fudge factor for turns and other obstacles, then cut off each section so that you have a bundle of wires you can pull at once.

Whenever you run the wire further than four and one half feet from a hole in a stud or joist (open attic space, going up walls, etc.), fasten the wire to the joists or studs using cable clamps or appropriately sized wire staples. The wire should not have large sags in it, nor should it be too tight. Try to protect the wire from being stepped on in attics or other unfinished crawl spaces. There are guard strips, raceways and conduits which can be used to protect the cable. Consult the local building code for special requirements in your area.

Concealing Speaker Wire in Existing Walls

This is actually a fairly simple task if you restrict your choice of speaker locations and wire routes to the interior walls or ceilings of your home. Interior walls in almost all North American residences are hollow, so that it is easy to flush mount speakers into them and route new speaker cable around the house. What you see when you look at the painted wall board, plaster, or paneling is only the skin of the wall. Behind the skin is the skeleton; two-by-four wood or metal “studs” running vertically from the floor to the ceiling in walls and two-by-six or larger “joists” running horizontally in the ceilings and floors. In between the studs and the joists is the space for the wiring and plumbing of your home.

Exterior walls are different. They must insulate the house from the heat and cold outside, so they are stuffed with insulation. The national building code requires that the hollow wall space in exterior walls be broken by a horizontal stud placed between the vertical studs. This “fire blocking” makes it very difficult to

retrofit long lengths of wire. In some areas of the country the exterior walls are constructed of solid masonry, and have no hollow space for speakers or wires.

Start by examining all the possible routes you might take to run the speaker wire from the speaker to the volume control and back to the stereo. Use a stud sensor or other device to locate the internal structure of the wall. You want to avoid all studs or joists. A typical route would be: from the speaker location up the inside of the wall to a new hole drilled into the top “plate” (horizontal two-by-four at the top of the inside of the wall), into the attic crawl space, then down to the volume control location through another top plate, back up to the attic, across the attic, and finally down another plate to the wall behind the stereo system itself (See Figure 4). The other very common route is through the bottom plate of the wall into an unfinished basement or crawl space.

Identify where all of your electrical, phone, and TV wiring is likely to be and plan to

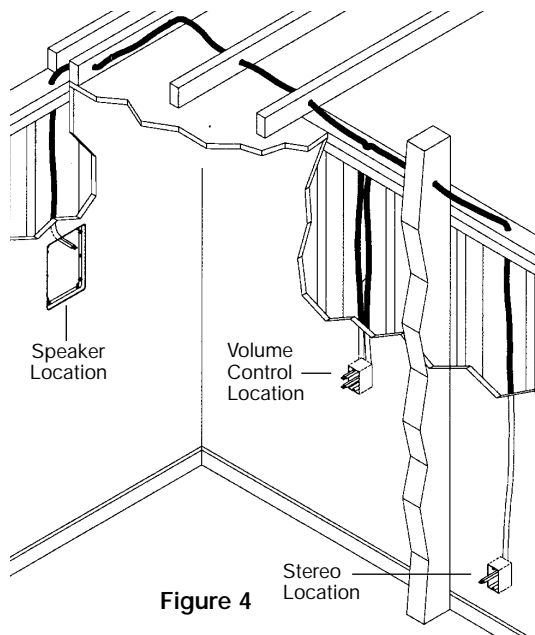

Figure 4

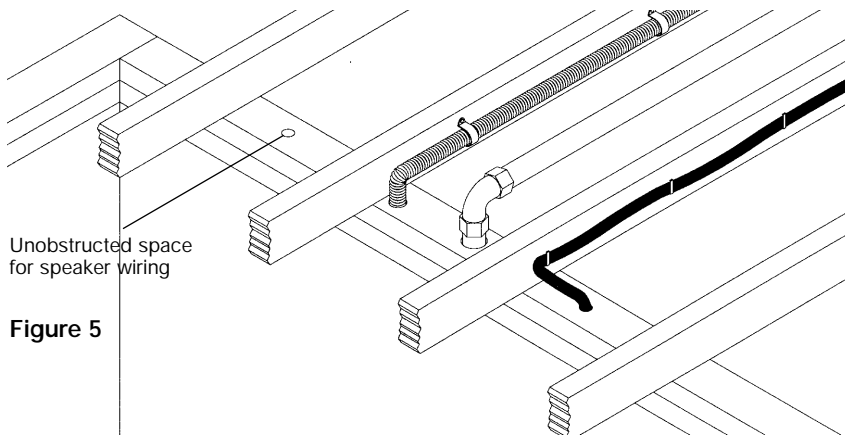

Figure 5

route around it all. You can accidentally induce 60 Hz hum on your speakers if you run your speaker wire right beside electrical wire for more than a few feet. Try to keep speaker wire running parallel to power cables at least 3 feet away. To find exactly where an electrical cable is routed, try inspecting the inside of the wall by turning off the breaker for a particular power outlet or switch, removing the cover plate and switch or receptacle, and shining a penlight into the wall. If you have access to an attic or basement space you can quickly see which part of the wall space the wire is free of obstructions (See Figure 5).

When you don't have access above or below the wall, try to estimate the existing wire and pipe locations from the positions of electrical outlets and plumbed fixtures on both sides of the wall. Take a look at the outside of your house too, sometimes conduit, vents or drain pipe will be visible that give useful information. Choose the route with the fewest potential obstacles.

If your house is built on a slab and you are wiring between two finished floors, look for baseboards which could be removed and replaced with the wire behind them. Doorjamb can be removed and often have enough space for speaker wire all the way around the door (See Figure 6).

Sometimes, an under-the-carpet run is possible (there are special flat speaker wires made for under-the-rug wire runs). As a last resort, heating and air conditioning vents can be used as wire raceways for plenum rated wire (check your local building codes, some municipalities require conduit).

Figure 6

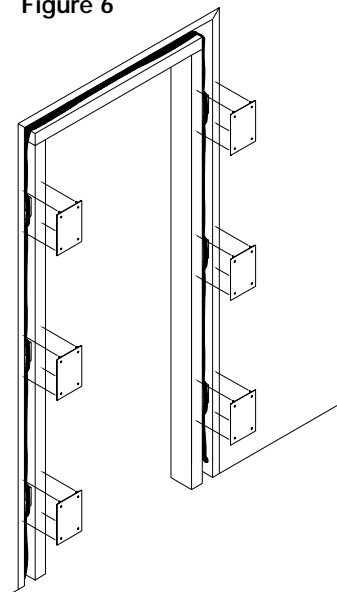
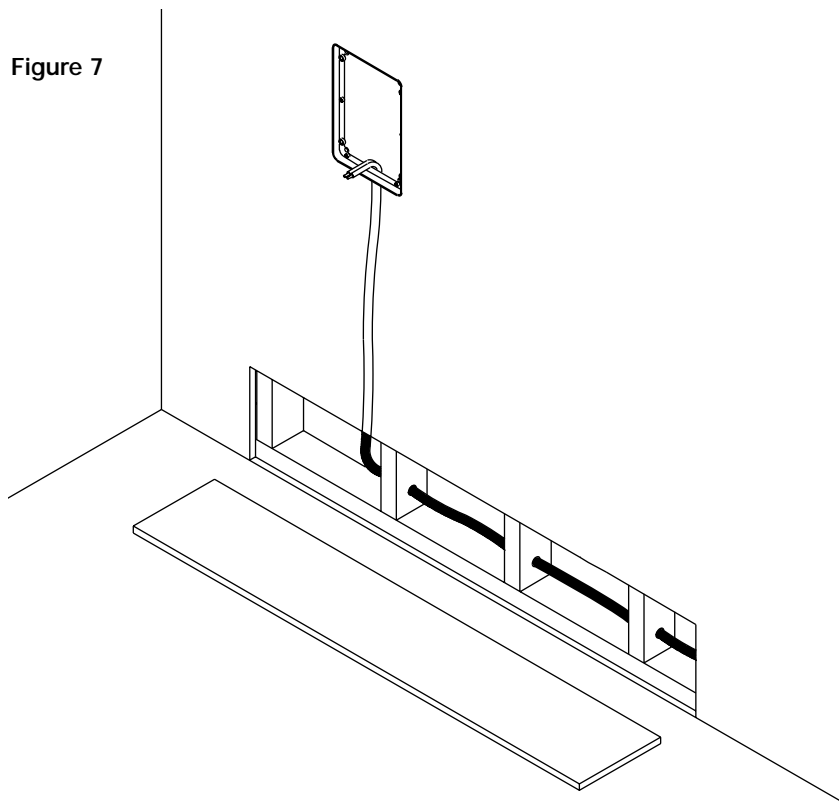

Figure 7



In traditional wood stud/drywall construction you can cut the hole for the speaker and utilize the large hole to auger holes across, up or down the wall for as far as your drill bit will take you. If you have matching paint and take reasonable care in patching you can cut a hatch in the drywall at each stud, run your wire, and patch and touch-up the wall (See Figure 7).

When you are dealing with the unknown because of the structure of your home, or with difficult to patch wall materials like plaster, lath and plaster, faux finishes, wall-paper etc., be patient. A careful study of the potential problems before you start the job will pay off.

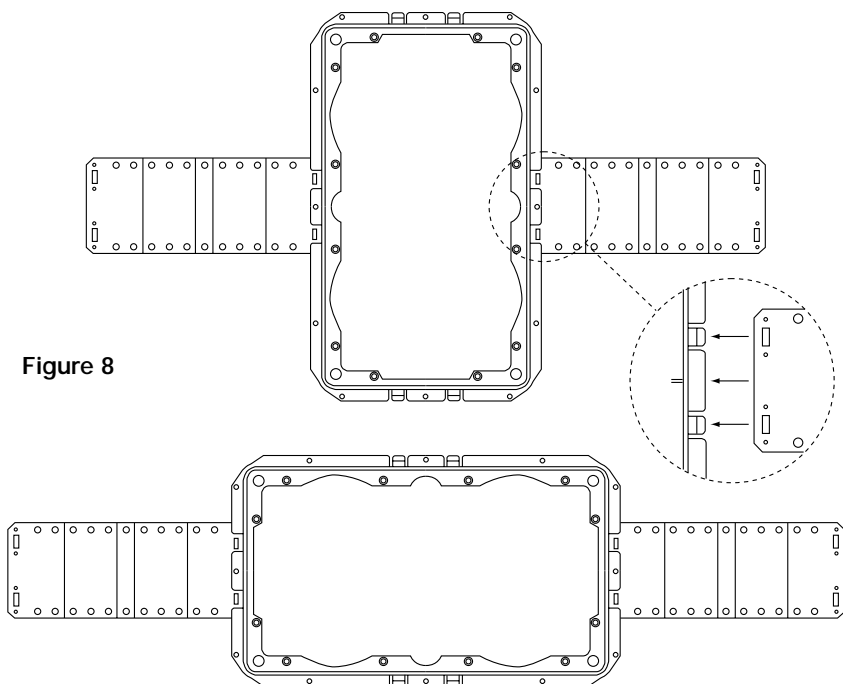

Figure 8

Installation of Brackets, Frames and Grilles in New Construction

Stage One: Before Drywall is Hung

Insulating the Wall Cavity.

If feasible, fill the wall cavity with insulation at this point.

Attach the wings to the bracket by snapping them into the sides of the bracket. The wings can be shortened by breaking them along the scored lines if their length will interfere with a corner or eaves. You can mount the bracket horizontally or vertically (See Figure 8).

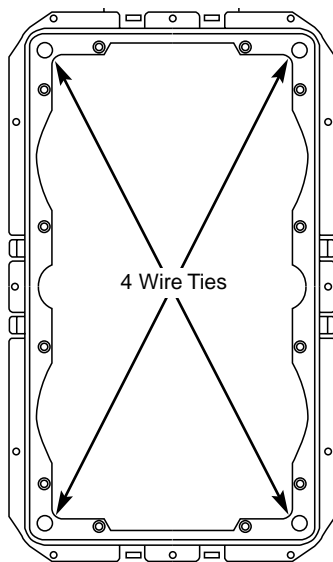
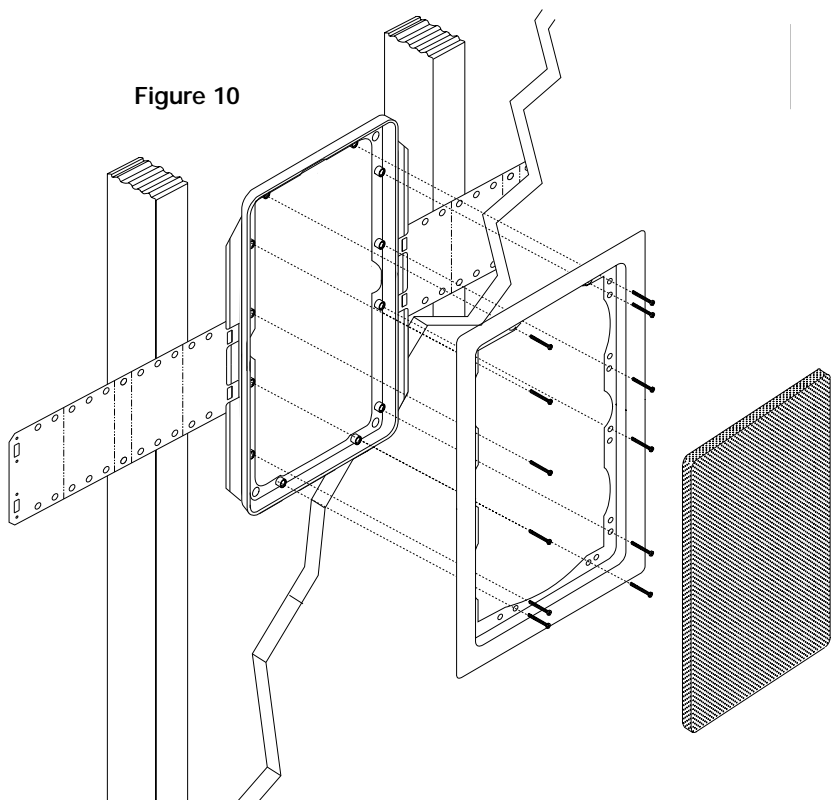

Figure 9

Figure 10



Screw one side of the assembled bracket with wings to the stud using one of the supplied screws. Level the bracket. Screw the other side of the bracket to the stud. Two or three screws (depending upon the size of the model) on each side makes for a very secure installation. Attach the wire to the bracket at the indicated wire tie points (See Figure 9).

Stage Two: Before Painting

Screw the frame to the installed bracket using the supplied screws. Do not overtighten the screws. This will distort the frame and the grilles will not fit (this is not permanent, just loosen the screws and the grille will pop in) (See Figure 10).

Painting the Aluminum Grilles

The grille is important to the sound of the AT loudspeakers. Do not fill the holes of the grille with paint. The grille is constructed of aluminum with a perfectly even powder coat overall. This powder coat is an ideal primer.

Remove the grilles before painting. If you are using spray paint, use two thin coats without any primer. If you are using a compressor and a spray gun, use the finest, most diffuse setting. Practice first on some paper if you have no experience painting with spray paint.

If you are using an applicator or brush, and a can of paint, thin the paint first. You do not want to have to poke hundreds of holes in your beautifully painted grilles.

Installation of Brackets, Frames and Grilles in Existing Walls

Important: Before you cut into any wall, review the sections on running wire and speaker placement.

1. Drill a 1/8" pilot hole just barely through the wallboard or dry wall (1/2" to 5/8" deep in most homes) about an inch below the center of your proposed speaker location (an inch to the side if you are mounting the speaker horizontally). **BE VERY CAREFUL NOT TO DRILL THROUGH EXISTING WIRES, PIPES, OR STRUCTURE.** If you feel any extra resistance as you are drilling, **STOP.** Cut a piece of coat hanger equal to the width of the bracket. Bend the wire in half creating a right angle. Poke the "L-shaped" wire into the pilot hole and turn it in a complete circle. If it turns freely, repeat the procedure from a hole about an inch above the center of your proposed speaker location (**See Figure 11**).

If the wire's movement is obstructed by a pipe or cable, fill the hole (s) with spackle or other patching compound and try another location.

2. When determining the final location of the cutout, keep in mind that the frame and bracket will extend beyond the cutout. Make sure that you do not place the edge of the cutout directly next to a stud. Locate the studs using a stud sensor or hand-knocking. Once you have determined the correct position for the cutout, hold the supplied template up to the wall surface. Level the template in either the horizontal or the vertical position and mark the wall with a pencil. Drill the four corners with a 1/4" drill bit.

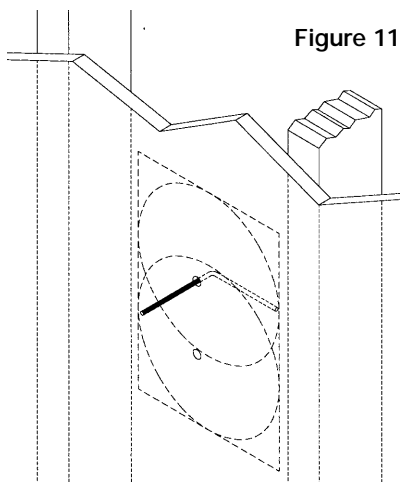

Figure 11

3. If you are cutting painted or wall papered drywall, use a sheetrock or key-hole saw. Cut the hole with the saw at a 45 degree angle. That way, the drywall section can be replaced cleanly if there is an unseen obstruction behind the wall. **BE VERY CAREFUL NOT TO SAW THROUGH EXISTING WIRES, PIPES, OR STRUCTURE.** If you feel any extra resistance as you are cutting, **STOP.**
4. If you are cutting into lath and plaster walls, use masking tape to outline your penciled marks, drill the four corners with a 1/4" bit and use a razor to score the plaster down to the lath beneath. Then use a chisel to remove all of the plaster within the taped outline. Finally, insert a metal cutting blade into a sabre saw and very slowly and carefully saw the lath. Sawing the lath can easily vibrate plaster off the wall. If you have the patience, use a pair of tin snips to slowly nip away at the lath instead. There is no risk with this method, it is just time consuming.
5. Fill the wall cavity with insulation at this point. Remember to use equal amounts of insulation for each speaker.
6. Slip the mounting bracket through the hole and pull it toward you so that its front edge slides into the hole and stops in place.

7. Attach the frame to the bracket by screwing the frame to the bracket using the supplied screws. Do not overtighten the screws, this will distort the frame and the grilles will not fit (this is not permanent, just loosen the screws and the grille will pop in). The screws should pull the frame and bracket together (sandwiching the drywall) so that the frame is absolutely flush with the wall surface. There should be no gaps between the wall and the frame (See Figure 12).

Installation of the Speaker and Grille in New or Existing Construction

Setting the Tone Controls

The AT8000 and AT8200 speakers feature baffle-mounted, 4 position level controls for the Bass, Midrange and Treble frequencies. These tone shaping filters enable each of the frequency bands to be cut or boosted

to compensate for less than ideal room acoustics, or to suit the listener's preference.

As an example, a speaker installed within one or two feet of a corner or ceiling may exhibit excessive bass response caused by the boundary effect. Cutting the Bass by 3 dB can minimize the boundary effect and enable the speaker to sound much more accurate and natural despite its proximity to the adjoining wall or ceiling. (For more information on the boundary effect, see **The Boundary Effect** on page 6.)

In contrast, a large room with lots of drapes, upholstered furniture and textured wall paper may sound dead and lifeless. Boosting the Treble 3dB or more may substantially increase the ambience and presence in an absorbent room.

The key to good sound is experimentation. Set the controls to the "flat" position to start with, then adjust until the desired results are achieved.

Installing a Niles MS-1 MicroSensor™

There is a 1/2" round molded "IR Sensor Knockout" on the face of the speaker baffle. To prevent damage to the crossover network, you must remove the knockout from the rear of the speaker. Do not attempt to remove the knockout with the speaker face up! Lay the speaker face down on a clean carpet or rug. Put the tip of a screwdriver into the center of the round "knockout" and sharply tap the screwdriver handle as necessary. Install the MS-1 using its mounting hex nut and washer so that it is tightly secured to the speaker. Connect all wires and continue your installation.

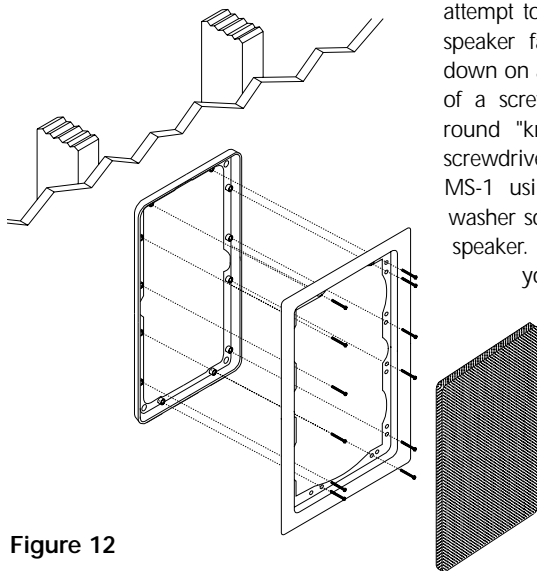

Figure 12

Installing the Speaker

If the grille is already installed, remove it by using a bent paper clip or the tip of a corkscrew and pulling it away from the frame (See Figure 13).

1. Separate the speaker wire so that at least two inches of each conductor are free.
2. Strip one half inch of insulation from the end of each conductor of the speaker wire.
3. If you have gold pin connectors which you wish to use, affix them to the stripped wire ends now.
4. Connect one stripped wire end (or connector) to the black and one to the red terminal. Pay attention to the markings on the wire. Each speaker must be connected to the amplifier in the same way.
5. Place the speaker baffle in the frame and secure it with the supplied #8 x 1/2" screws. If you find that the baffle does not smoothly fit the frame, slightly loosen the mounting screws that hold the frame to the bracket.
6. Carefully fit the grille into its recess so that it is barely in place. Starting with one corner, go around the speaker, pushing the grille in a little bit each time. You should be gentle, the aluminum grille can be easily bent out of shape. The speaker will have an absolutely flush appearance when it is fully in place.

Speaker Phase

Speaker wire has two conductors. One conductor is attached to the negative (-) terminals and one conductor is attached to the positive (+) terminals of both your speaker and your amplifier. Usually, the wire is marked for your convenience. There are different ways wires are marked: a stripe on one wire, a ribbed area of one

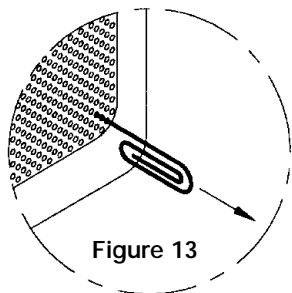

Figure 13

conductor you can only feel, different colors of metal wire on each conductor, or there might be a fabric strand or string wound into one of the conductors. Of course, there are some wires which appear completely identical. Be careful, or you might make a mistake.

If you make a mistake, one speaker will be playing "out-of-phase" with the other speaker. An out-of-phase pair of speakers work against each other and the sound of the two speakers playing together will be lacking in bass and be "phasey" sounding. If you suspect the sound is not right and you cannot see any markings on the wire, try this simple test:

1. Stand half way between the two speakers.
2. Play some music with the amplifier or radio set to Mono.
3. Listen to the richness of the bass and the loudness of the sound.
4. Turn off the amplifier and reverse the connections on one amplifier channel only.
5. Repeat the listening test with the same setting of the volume control. When the sound has a richer bass and is slightly louder, the speakers are working together or "in-phase".

Operation

Listening at Higher Volumes

It requires more power to achieve a reasonable volume of sound in a large room than it does in a small room. It is possible (even if you are not a teenager) to turn the volume so high that the amplifier runs out of power. This creates “clipping” distortion.

Clipping distortion makes treble sound very harsh and unmusical. When you hear harsh sounding treble from any good speaker, turn the volume down immediately! Those harsh sounds are masking some much more powerful ultra-high-frequency sound spikes which will quickly damage any fine loudspeaker. You are much less likely to damage a speaker with a large amplifier because it will be very loud indeed before it produces any clipping distortion.

Cleaning

You can clean the speaker with a dampened soft cloth or paper towel. If the speaker is mounted high up on a wall or ceiling, use a broom to gently brush it off.

Specifications

Model AT8000

Driver Compliment

WOOFER — 8" Interlaced carbon/glass fiber cone with an inverted dust cap, butyl rubber suspension and a custom construction debris screen

MIDRANGE — 1-1/2" fluid-cooled tri-laminate hyperbolic dome with a NDFE 35 neodymium, high magnetic flux motor structure and distortion canceling balanced drive

TWEETER — 1" fluid-cooled tri-laminate hyperbolic dome in a zero diffraction swiveling enclosure with a NDFE 35 neodymium, high magnetic flux motor structure and distortion canceling balanced drive

Crossover

Computer-optimized, Linkwitz-Riley filters with premium components and 4 increment (-2dB; Flat; +2dB; +4dB) Bass, Midrange, and Treble controls

Design Principle

Infinite baffle for large and varying air volumes

Recommended Amplifier Power

Twenty to Two Hundred watts per channel RMS

Nominal Impedance

8 Ohms (4 Ohms minimum)

Frequency Response

30 Hz to 21,000 Hz, plus or minus 3dB (on axis)

Sensitivity

89 decibels for 2.83 volts of Pink Noise, measured at 1 meter on axis

Maximum Sound Pressure Level

112dB

Overall Exterior Frame Dimensions

11" x 18-3/8"

Depth Behind Wall

3-1/8" (Assumes 1/2" drywall)

Wall Cut-Out Dimensions

9-3/4" x 17-1/4"

Wiring Requirements

We recommend 16 to 18 gauge for up to 80 feet, 14 gauge for up to two hundred feet. Connectors accommodate 8 to 22 gauge wire.

Model AT8200

Driver Compliment

WOOFER — 8" aluminum/urethane cone with a high temperature aluminum voice coil former, an inverted dust cap, a butyl rubber suspension and a custom construction debris screen

MIDRANGE — 1-1/2" fluid-cooled aluminum/urethane hyperbolic dome with a NDFE 35 neodymium, high magnetic flux motor structure and distortion canceling balanced drive

TWEETER — 1" fluid-cooled aluminum/urethane hyperbolic dome with a NDFE 35 neodymium, high magnetic flux motor structure and distortion canceling balanced drive

Crossover

Computer-optimized, Linkwitz-Riley filters with premium components and 4 increment (-2dB; Flat; +2dB; +4dB) Bass, Midrange, and Treble controls

Design Principle

Infinite baffle for large and varying air volumes

Recommended Amplifier Power

Twenty to Two Hundred watts per channel RMS

Nominal Impedance

8 Ohms (4 Ohms minimum)

Frequency Response

30 Hz to 21,000 Hz, plus or minus 3dB (on axis)

Sensitivity

89 decibels for 2.83 volts of Pink Noise, measured at 1 meter on axis

Maximum Sound Pressure Level

114dB

Overall Exterior Frame Dimensions

11" x 18-3/8"

Depth Behind Wall

3-1/8" (Assumes 1/2" drywall)

Wall Cut-Out Dimensions

9-3/4" x 17-1/4"

Wiring Requirements

We recommend 16 to 18 gauge for up to 80 feet, 14 gauge for up to two hundred feet. Connectors accommodate 8 to 22 gauge wire.

Limited Warranty

Niles Audio Corporation ("NILES") warrants its loudspeaker products to the original purchaser to be free of manufacturing defects in material and workmanship for a period of two years from date of purchase.

This Warranty is subject to the following additional conditions and limitations. The Warranty is void and inapplicable if NILES deems that the product has been used or handled other than in accordance with the instructions provided by the manufacturer, including but not limited to damage caused by accident, mishandling, improper installation, abuse, negligence, or normal wear and tear, or any defect caused by repair to the product by anyone other than NILES or an authorized NILES dealer.

To obtain warranty service, take the unit to the nearest authorized NILES dealer, who will test the product and if necessary, forward it to NILES for service. If there are no authorized NILES dealers in your area, you must write to NILES and include your name, address, model and serial number of your unit, along with a brief description of the problem. A factory Return Authorization Number will be sent to you. **DO NOT RETURN ANY UNIT WITHOUT FIRST RECEIVING WRITTEN AUTHORIZATION AND SHIPPING INSTRUCTIONS FROM NILES.**

If the above conditions are met, the purchaser's sole remedy shall be to return the product to NILES, in which case NILES will repair or replace, at its sole option, the defective product without charge for parts or labor. NILES will return a unit repaired or replaced under warranty by shipping same by its usual shipping method from the factory (only) at its expense within the United States of America. **THERE ARE NO OTHER WARRANTIES, INCLUDING WITHOUT LIMITATION, EITHER EXPRESS OR IMPLIED WARRANTIES OF MERCHANTABILITY OR FITNESS FOR A PARTICULAR PURPOSE, WITH RESPECT TO THE PRODUCT.**

REPAIR OR REPLACEMENT AS PROVIDED UNDER THIS WARRANTY IS THE EXCLUSIVE REMEDY OF THE CONSUMER/PURCHASER. NILES SHALL NOT BE RESPONSIBLE FOR ANY INCIDENTAL OR CONSEQUENTIAL DAMAGES EXCEPT TO THE EXTENT PROVIDED (OR PROHIBITED) BY APPLICABLE LAW.

Some states do not allow the exclusion or limitation of incidental or consequential damages, so the above limitation may not apply to you. This warranty gives you specific legal rights, and you may also have other rights which vary from state to state.

For the name of your nearest authorized NILES dealer contact:

NILES AUDIO CORPORATION
 P.O. BOX 160818, Miami, Florida 33116-0818.

Please fill in your product information and retain for your records.

Model _____

Serial No. _____

Purchase Date _____

WARRANTY REGISTRATION CARD

Model Purchased _____

Serial Number _____

Date Purchased (month/day/year) _____

Dealer Name and Location _____

Dr. Miss Mr. Mrs. Ms.

Name _____

Address _____

City _____ State _____ Zip _____

Telephone (_____) _____



Please take a moment to fill out our warranty registration card. The information helps us to get to know you better and develop the products you want

Age:

- Under 25
- 25-34
- 35-44
- 45-54
- 55 & over

Income:

- Under \$24,999
- \$25,000-\$34,999
- \$35,000-\$44,999
- \$45,000-\$59,999
- \$60,000-\$74,999
- \$75,000-\$99,999
- Over \$99,999

Occupation:

- Arts/Entertainment
- Business Owner
- Engineer
- Finance/Accounting
- General Office
- Management
- Professional
- Sales/Marketing
- Student
- Tradesperson

Musical tastes:

(Please check all that apply)

- Alternative
- Classical
- Country
- Jazz
- New Age
- Popular
- R&B
- Rock
- Other _____

How did you hear about Niles?

- Architect/Developer
- Custom Installer
- Direct Mail
- Friend/Family
- In-Store Display
- Interior Designer
- Magazine Ad
- Mail-Order Catalog
- Newspaper Ad
- Product Brochure
- Product Review
- Retail Salesperson

What magazines do you read?

1. _____
2. _____
3. _____

Who will install the product?

- Custom Installer
- Electrician
- Friend
- Myself

Which factor(s) influenced the purchase of your Niles product?

(Please check all that apply)

- Ease of Use
- Price/Value
- Product Features
- Quality/Durability
- Reputation
- Style/Appearance

Warranty Do you . . . ?

Own a House. If yes, how many square feet? _____

Own a Town House/Condominium/Co-op

Rent an Apartment

Rent a House

Are you interested in receiving literature on other Niles products?

Yes No

Are there products/capabilities that you would like to see introduced?

PLEASE FILL OUT THE
WARRANTY REGISTRATION
CARD ON THE REVERSE
SIDE, DETACH, AND MAIL
TO:

**Niles Audio Corporation
Warranty Registration Dept.
P.O. Box 160818
Miami, Florida 33116-0818**

DETACH HERE





NILES®

Niles Audio
Corporation

12331 S.W. 130 Street
Miami, Florida 33186
Tel: (305) 238-4373
Fax: (305) 238-0185
www.nilesaudio.com

Printed in Taiwan

© 1998 Niles Audio Corporation DS00220A